

NOTICE OF
CHANGE

INCH-POUND

MIL-STD-2088A
NOTICE 1
05 May 1997

DEPARTMENT OF DEFENSE
DESIGN CRITERIA STANDARD

BOMB RACK UNIT (BRU), AIRCRAFT, GENERAL DESIGN CRITERIA FOR
TO ALL HOLDERS OF MIL-STD-2088A

1. The following pages of MIL-STD-2088A have been revised and supersede the pages listed:

NEW PAGE	DATE	SUPERSEDED PAGE	DATE
5	05 May 1997	5	20 May 1994
6	05 May 1997	6	20 May 1994
15	20 May 1994	15	Reprinted without change
16	05 May 1997	16	20 May 1994
17	05 May 1997	17	20 May 1994
18	20 May 1994	18	Reprinted without change

2. Retain the Notice and insert before Table of Contents.

3. Holders of MIL-STD-2088A will verify that page changes and additions indicated above have been entered. This issuance, together with appended pages, is a separate publication. Each notice is to be retained by stocking points until the standard is completely revised or canceled.

Custodians:
Army - AV
Navy - AS
Air Force - 11

Preparing activity:
Navy - AS
(Project 1095-0300)

AMSC N/A

FSC 1095

DISTRIBUTION STATEMENT A. Approved for public release; distribution is unlimited.

MIL-STD-2088A

HANDBOOKS

MILITARY

- MIL-HDBK-5 Metallic Materials and Elements for Aerospace Vehicle Volumes 1 and 2 Structures
- MIL-HDBK-235-1 Electromagnetic (Radiated) Environment Considerations for Design and Procurement of Electrical and Electronic Equipment, Subsystems and Systems

(Unless otherwise indicated, copies of federal and military specifications, standards, and handbooks are available from the Standardization Documents Order Desk, 700 Robbins Avenue, Building 4D, Philadelphia, PA 19111-5094.)

2.1.2 Other Government documents, drawings, and publications. The following other Government documents, drawings, and publications form a part of this standard to the extent specified herein.

DRAWINGS

NAVAL SEA SYSTEMS COMMAND (CAGE Code 10001)

- 2263759 Latch, Spring Assembly
- 422872 Arming Wire, Single, MK 1 MOD 0, Arming Wire, Double, MK 2 MOD 0

(Unless otherwise indicated, copies of Naval Sea Systems Command drawings are available from the Naval Ordnance Station (Code 802), Louisville, KY 40214-5001.)

NAVAL AIR WARFARE CENTER

- (30003) 1380547 Body assembly, bomb (500 lb)
- 2841466 Body assembly, bomb (1000 lb)
- 923AS101 Body assembly, bomb (2000 lb)

(Copies are available from Commander, Naval Air Warfare Center Weapons Division (Code 332200E, Attn: Data Management), 550 Stinson Avenue, Building 248, Room 230, Camarillo, CA 93010.)

PUBLICATIONS

MILITARY

SUPERSEDES PAGE 5 OF MIL-STD-2088A.

MIL-STD-2088A

MIL-BUL-147 Specifications and Standards of Non-Government Organizations Released for Flight Vehicle Design and Construction

(Unless otherwise indicated, copies of military bulletins are available from the Standardization Documents Order Desk, 700 Robbins Avenue, Building 4D, Philadelphia, PA 19111-5094.)

NAVAL AIR SYSTEMS COMMAND

AR-43 Electromagnetic Compatibility Advisory Board; Requirement for

SD-24 General Specification for Design and Construction of Aircraft Weapon Systems

WS-2081 Switch, Arming Safety, Mark 122 Mod 0

(Copies of AR-43, SD-24, and WS-2081 are available from the Naval Air Systems Command, Standardization Section (AIR-4.1C), 1421 Jefferson Davis Highway, Arlington, VA 22243-5110.)

NORTH ATLANTIC TREATY ORGANIZATION (NATO)

STANAG 3575 Ed.5 Aircraft Stores Ejector Racks

AIR STANDARDIZATION COORDINATING COMMITTEE (ASCC)

AIR STD 20/10 Ejector Release Units for Aircraft Stores

AIR STD 20/16 Electromagnetic Compatibility of Aircraft Electroexplosive Subsystems

AIR STD 20/17 Mechanical Connectors Between Stores and Suspension Equipment for Arming and Associated Functions of Stores

AIR STD 20/18 Laboratory Tests for Stores Suspension Equipment

(Unless otherwise indicated, copies of STANAGs and AIR STDs are available from the Standardization Documents Order Desk, 700 Robbins Avenue, Building 4D, Philadelphia, PA 19111-5094.)

2.2 Order of precedence. In the event of a conflict between the text of this document and the references cited herein, the text of this document takes precedence. Nothing in this document, however, supersedes applicable laws and regulations unless a specific exemption has been obtained.

SUPERSEDES PAGE 6 OF MIL-STD-2088A

MIL-STD-2088A

requirements of MIL-STD-100 shall govern the part numbers and changes thereto.

4.5 Identification and marking. Identification and marking shall be in accordance with MIL-STD-130. Nameplates for equipment identification shall be in accordance with MIL-P-15024, Size 3, Type A (c) or H, Style III and MIL-N-18307. All parts shall be marked with part numbers and, if applicable, lot numbers. Specifications on engineering drawings shall provide for part marking and shall indicate location of marking for accessibility.

5. DETAILED REQUIREMENTS

5.1 Loading (see 3.3) of stores. The BRU/store interface shall be designed with adequate space provisions to allow safe, rapid loading and off-loading of all applicable stores with a minimum of personnel, no peculiar equipment or tools required. This interface shall provide good visibility and easy access to all controls, connections, switches and devices that relate to store loading/off-loading operations and positive visual determination of status of store installation. Consideration shall be given to store handling equipment installation (including manual loading equipment) and hook-lug entry angle during loading/off-loading operations. BRU geometry shall provide for the proper application of existing non-permanent hoisting adapters, hoisting devices including manual loading equipment, and loading carts or trucks as specified herein. All loading and off-loading or related equipment attachment or installation points shall be clearly marked and identified as to proper usage. For Navy aircraft applications, any BRU loading attachments or hoisting components shall be capable of withstanding a vertical limit loading of 2.67 g and carrier roll rates of $\pm 20^\circ$ with a 17 second period and pitch of $\pm 3^\circ$ with an 8 second period. BRU/store interface shall be compatible with the controls, load application range, and operational requirements of current applicable U.S. inventory support equipment including Single Hoist Ordnance Loading System (SHOLS) (see MIL-I-8671). In addition, the interface shall provide compatibility with manual loading equipment such that stores up to and including the 1,000 pound class can be loaded rapidly and safely with a minimum of personnel and without special tools or equipment. All connections or disconnections; ie, arming wire installation, cartridge installation, fuzing connections, and safety interlock function required during this sequence of events, shall be accomplished after the store is structurally attached to the BRU without releasing the store attachment (AIR STD 20/17).

5.1.1 Support Equipment (SE). The BRU shall be designed to be capable of being installed, tested, serviced and maintained using standard SE and hand tools. Use of common hand tools shall be maximized. All SE shall be identified and grouped by maintenance level (Organizational and Intermediate).

5.1.2 Engagement, latching, and vertical support (see 3.7). The activation of the BRU vertical support latches (see 3.2) shall be automatic upon engagement of the store, independent of each other, and their position shall be visually discernible on both sides without requiring power. Overcenter latching devices, such as toggles and cams, if used, shall be designed and installed in such a way as to provide positive latching and unlatching and shall be insensitive enough to preclude inadvertent unlatching due to vibrations, tolerance build up, wear or structural deflections under load. Latching devices shall have a minimum travel of 15° from the latched to overcenter position. The vertical supports shall be designed such that they are either latched or unlatched with no in-between position. The vertical support system shall consist of two hooks to support 14-inch or 30-inch suspension store or four symmetrically positioned hooks for systems requiring

MIL-STD-2088A

14 and 30-inch suspension. BRU lower surface to store upper surface clearance shall be as specified in MIL-A-8591 (STANAG 3575 Ed.5 and AIR STD 20/10). After a store has been released, the latching system shall engage and latch the next loaded store without additional actions of the loading crew. The vertical latching force required to engage the store shall not exceed 25 pounds per hook for Type I BRUs and 50 pounds per hook for Type II BRUs. The vertical support shall be located as shown in Figure 1 and Figure 2. Ejector feet shall not impact the weld areas as defined in NAVAIR bomb assembly drawings (30003) 923AS101, 2841466 and 1380547.

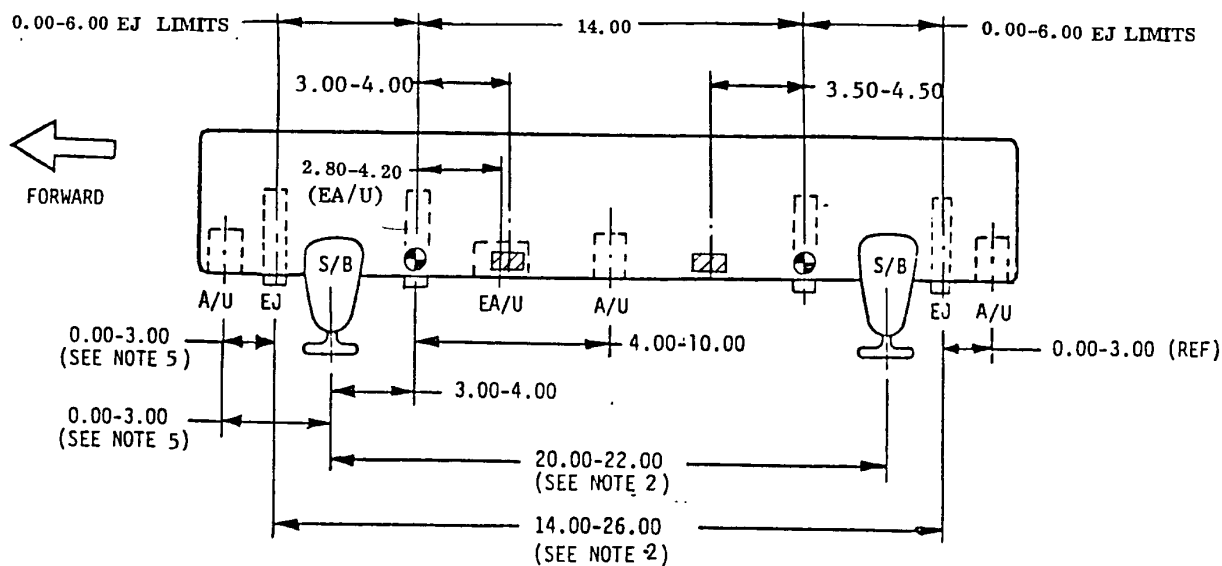

Notes:

1. Dimensions are in inches.
2. Dimensions are symmetrical about the midpoint of the 14-inch hook spacing.
3. Legend:
 - S/B = Sway brace
 - A/U = Mechanical fuze arming unit
 - EA/U = Electrical fuze arming unit (MK 39 receptacle)
 - EJ = Ejector
 - ⊙ = Store suspension hook
 - ▨ = Positive arming attachment
4. All dimensional limit lines are located at \bar{C} of feature
5. Fore and aft A/Us shall be located 0.00-3.00 inches outboard of the outer most interface feature (sway brace or ejector piston).

FIGURE 1. 14-inch hook spacing, Type I, bomb rack unit (BRU) geometric relationships.

SUPERSEDES PAGE 17 OF MIL-STD-2088A

MIL-STD-2088A

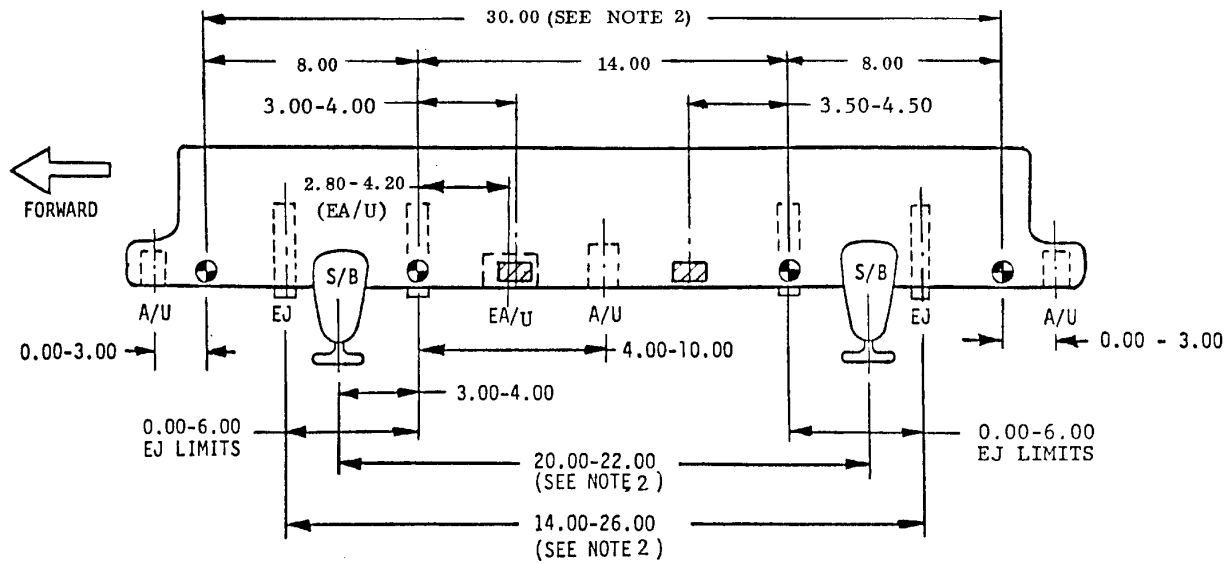

Notes:

1. Dimensions are in inches.
2. Dimensions are symmetrical about the midpoint of the 14-inch hook spacing.
3. Legend:

- S/B = Sway brace
- A/U = Mechanical fuze arming unit
- EA/U = Electrical fuze arming unit (MK 39 receptacle)
- EJ = Ejector
- ⊗ = Store suspension hook
- ▨ = Positive arming attachment

4. All dimensional limit lines are located at \square of feature

FIGURE 2. 14/30-inch hook spacing, Type II, bomb rack unit (BRU) geometric relationships.

REPRINTED WITHOUT CHANGE

INCH-POUND

MIL-STD-2088A

9 MAY 1994

SUPERSEDING

MIL-STD-2088

MILITARY STANDARD
BOMB RACK UNIT (BRU),
AIRCRAFT, GENERAL DESIGN CRITERIA FOR



AMSC N/A

FSC 1095

DISTRIBUTION STATEMENT A. Approved for public release; distribution is unlimited.

MI L-STD-2088A

FOREWARD

1. This military standard is approved for use by all Departments and Agencies of the Department of Defense.
2. Beneficial comments (recommendations, additions, deletions) and any pertinent data which may be of use in improving this document should be addressed to: Commander, Naval Air Warfare Center Aircraft Division, Code SR3, Highway 547, Lakehurst, NJ 08733-5100, by using the self-addressed Standardization Document Improvement Proposal (DD Form 1426) appearing at the end of this document or by letter.

CONTENTS

<u>PARAGRAPH</u>		PAGE
1.	SCOPE.	1
1.1	Scope.	1
1.1.1	International coordination	1
1.2	Classification	1
2.	REFERENCED DOCUMENTS	2
2.1	Government documents	2
2.1.1	Specifications, standards, and handbooks	2
2.1.2	Other Government documents, drawings, and publications	5
2.2	Order of precedence	6
3.	DEFINITIONS.	7
3.1	Aircraft store	7
3.2	Latch	7
3.3	Loading	7
3.4	Primary release	7
3.5	Secondary release	7
3.6	Sway bracing	7
3.7	Vertical supports	7
4.	GENERAL REQUIREMENTS.	8
4.1	BRU types	8
4.2	Selection of materials, specifications, standards, and drawings	8
4.2.1	Materials	8
4.2.1.1	Metal parts	8
4.2.1.1.1	Heat treatment	8
4.2.1.1.2	Castings	8
4.2.1.1.3	Forgings	8
4.2.1.2	Non-metallic components	8
4.2.1.2.1	Reinforced plastic construction	9
4.2.1.3	Lubrication	9
4.2.1.4	Hydraulic fluids	9
4.2.1.5	Fungus-proof materials	9
4.2.1.6	Potting compounds	9
4.2.1.7	Corrosion protection	9
4.2.1.8	Finishes	9
4.2.1.8.1	Anodizing	9
4.2.1.8.2	Chemical surface treatment	9
4.2.1.8.3	Plating	10
4.2.1.9	Electrical connectors	10
4.2.1.10	Wiring	10
4.2.1.11	Soldered or brazed connections	10
4.2.2	Specifications and standards	10
4.2.3	Drawings	10
4.3	General design requirements	10
4.3.1	BRU to aircraft installation	10
4.3.2	Design factors of safety	10
4.3.2.1	Yield	10
4.3.2.2	Ultimate	10

CONTENTS

<u>PARAGRAPH</u>		<u>PAGE</u>
4.3.2.3	Pressure system	11
4.3.3	Structural load requirements	11
4.3.4	Stress analysis	11
4.3.5	Service life	11
4.3.6	Reliability	11
4.3.7	Interfaces	11
4.3.7.1	BRU to aircraft Interface	11
4.3.7.2	BRU to store interface	11
4.3.7.3	Electrical grounding Interface	12
4.3.7.3.1	BRU to aircraft structure grounding	12
4.3.7.3.2	BRU internal ground Interface	12
4.3.8	Human engineering	12
4.3.9	Environmental and service conditions	13
4.3.10	Maintainability	13
4.3.10.1	Maximum maintenance time	13
4.3.10.2	Ejector system maintainability	13
4.3.10.3	Ejector system maximum maintenance time	14
4.3.10.4	Maintenance plan	14
4.3.10.4.1	Organizational maintenance	14
4.3.10.4.1.1	Organizational maintenance tasks	14
4.3.10.4.2	Intermediate maintenance	14
4.3.10.4.2.1	Intermediate maintenance tasks	14
4.4	Interchangeability	14
4.5	Identification and marking	15
5.	DETAILED REQUIREMENTS	16
5.1	Loading of stores	16
5.1.1	Support Equipment (SE).	16
5.1.2	Engagement, latching, and vertical support	16
5.1.3	Store sensing.	19
5.1.3.1	Store sensing failure mode	19
5.1.4	Fuzing and arming control	19
5.1.4.1	Mechanical fuze AUs.	19
5.1.4.2	Electrical fuze AU	20
5.1.4.3	Positive arming attachment.	20
5.1.5	Swaybraces.	20
5.1.6	Safety interlock	21
5.1.6.1	Safety interlock override system	21
5.1.6.2	Safety interlock electrical sensing	22
5.1.7	Store release and ejection system	22
5.1.7.1	Cartridge initiation	22
5.1.7.2	Cartridges	22
5.1.7.3	Cartridge firing pin.	25
5.1.7.4	Cartridge breech	25
5.1.7.5	Ejection force	25
5.1.7.6	BRU to aircraft reaction	26
5.1.7.7	Separation velocity	26
5.1.7.8	Ejection pistons	26
5.1.8	Safety in design	26
5.1.8.1	BRU safety program.	26
5.1.8.1.1	Safety program functions	26

CONTENTS

<u>PARAGRAPH</u>	<u>PAGE</u>
5.1.8.1.2	Failure modes and criticality effects analysis . . . 27
5.1.8.1.3	Inadvertent release 27
5.1.8.1.4	Locked shut functioning 27
5.1.8.1.5	Driven Items. 27
5.1.8.1.6	Impulse cartridges 27
5.1.9	Electromagnetic Environmental Effects (E ³). 27
5.1.9.1	Electromagnetic Compatibility (EMC) program 27
5.1.9.2	Electromagnetic Interference (EMI) 27
5.1.9.2.1	Electromagnetic Pulse (EMP) 27
5.1.9.3	Electromagnetic Vulnerability (EHV) 29
5.1.9.4	Lightning protection 29
5.1.9.5	Bonding and grounding 29
5.1.9.6	Wiring and cabling 29
5.1.9.7	Static electricity 29
5.1.9.8	Hazards of Electromagnetic Radiation to Ordnance (HERO) 29
5.1.9.9	Coupling Factor (CF) 29
5.2	Detailed electrical requirements 29
5.2.1	General 29
5.2.2	Rack structural ground 29
5.2.3	Nose arm 29
5.2.4	Tail arm 29
5.2.5	Electrical fuzing 30
5.2.6	Primary release command 30
5.2.6.1	Impulse cartridge 30
5.2.6.2	Solenoid release 30
5.2.7	Secondary release command 30
5.2.8	Auxiliary release command 30
5.2.9	In-flight Operable Bomb Rack Lock (IFOBRL) Lock command 30
5.2.10	IFOBRL unlock command. 30
5.2.11	IFOBRL Lock monitor 30
5.2.12	IFOBRL unlock monitor 31
5.2.13	IFOBRL Lock override. 31
5.2.14	IFOBRL Cartridge Activated Device (CAD) auxiliary unlock command 31
5.2.15	Hook status. 31
5.2.16	Rack present 31
5.2.17	Store sense switch. 31
5.2.18	Rack power/master arm 32
6.	NOTES. 32
6.1	Intended use 32
6.2	Issue of DoDISS. 32
6.3	Consideration of data requirements 32
6.4	International standardization agreements 32
6.5	Subject term (key word) listing 33
6.6	Changes from previous issue 33
	CONCLUDING MATERIAL 34

MIL-STD-2088A

CONTENTS

<u>FIGURE</u>		<u>PAGE</u>
1	14-inch hook spacing, Type I, bomb rack unit (BRU) geometric relationships. . .	17
2	14/30 inch hook spacing, Type II, bomb rack unit (BRU) geometric relationships. . .	18
3	Wiring schematic to achieve primary and secondary release	23
4	CCU-43/B, CCU-44/B, CCU-45/B cartridges functioning the vs applied current	24
 <u>TABLE</u>		
I	Carriage characteristics of BRU types	8
II	RS03 test levels.	28
III	Worst-case modulation over required frequency band.	28
IV	Modulation fall back values	28
V	Paragraphs containing international standardization agreements.	33

1. SCOPE

1.1 Scope. This standard establishes the general guidelines and criteria for the design and development of a bomb rack unit (BRU) for carriage and power-ejection release of airborne stores (excluding air-to-air-missiles) on 14 or 30-inch suspension from fixed wing aircraft. Mechanical aircraft armament interoperable interfaces are incorporated to enhance cross utilization and servicing capabilities between military aircraft and aircraft stores (see 3.1) of all services of the Department of Defense (DOD) and North Atlantic Treaty Organization (NATO) countries.

1.1.1 International coordination. Included in this standard are certain DOD acceptable interface configurations which are approved or currently undergoing international coordination and are incorporated into appropriate International standardization documents (see 6.4).

1.2 Classification. The BRU are of the following types as specified:

Type I - 14-inch, maximum carriage mass 1450 pounds

Type II - 14/30-inch, maximum carriage mass 1450 pounds for 14-inch and 5000 pounds for 30-inch.

2. REFERENCED DOCUMENTS

2.1 Government documents.

2.1.1 Specifications, standards, and handbooks. The following specifications, standards, and handbooks form a part of this document to the extent specified herein. Unless otherwise specified, the issues of these documents are those listed in the issue of the Department of Defense Index of Specifications and Standards (DoDISS) and supplement thereto, cited in the solicitation (see 6.2).

SPECIFICATIONS

FEDERAL

L-P-383	Plastic Material, Polyester Resin, Glass Fiber Base, Low Pressure Laminated
QQ-A-367	Aluminum Alloy Forgings
QQ-P-416	Plating, Cadmium (Electrodeposited)

MILITARY

MIL-S-4040	Solenoid. Electrical, General Specification for
MIL-S-5002	Surface Treatments and Inorganic Coatings for Metal Surfaces of Weapon Systems
MIL-B-5087	Bonding, Electrical, and Lightning Protection, for Aerospace Systems
MIL-W-5088	Wiring, Aerospace Vehicle
MIL-C-5541	Chemical Conversion Coatings on Aluminum and Aluminum Alloys
MIL-H-5606	Hydraulic Fluid, Petroleum Base, Aircraft, Missile and Ordnance
MIL-E-6051	Electromagnetic Compatibility Requirements, Systems
MIL-H-6088	Heat Treatment of Aluminum Alloys
MIL-H-6875	Heat Treatment of Steel Process for
MIL-F-7179	Finishes, Coatings, and Sealants, for the Protection of Aerospace Weapons Systems
MIL-F-7190	Forging, Steel, for Aircraft/Aerospace Equipment and Special Ordnance Applications
MIL-T-7743	Testing, Store Suspension and Release Equipment, General Specification for

MIL-STD-2088A

SPECIFICATIONS - Continued.

MILITARY

MIL-B-7883	Brazing of Steels, Copper, Copper Alloys, Nickel Alloys, Aluminum and Aluminum Alloys
MIL-A-8591	Airborne Stores, Suspension Equipment and Aircraft-Store Interface (Carriage Phase); General Design Criteria for
MIL-A-8625	Anodic Coatings, for Aluminum and Aluminum Alloys
MIL-I-8671	Installation of Droppable Stores and Associated Release Systems
MIL-C-8837	Coating, Cadmium (Vacuum Deposited)
MIL-P-15024	Plates, Tags and Bands for Identification of Equipment
MIL-F-18264	Finishes: Organic, Weapons System, Application and Control of
MIL-N-18307	Nomenclature and Identification for Aeronautical Systems Including Joint Electronics Type Designated Systems and Associated Support Systems
MIL-A-21180	Aluminum Alloy Castings, High Strength
MIL-A-22771	Aluminum Alloy Forgings, Heat Treated
MIL-C-38999	Connectors, Electrical, Circular, Miniature, High Density, Quick Disconnect, (Bayonet, Threaded, and Breech Coupling) Environment Resistant, Removable Crimp and Hermetic Solder Contacts, General Specification for
MIL-L-46010	Lubricant, Solid Film, Heat Cured, Corrosion Inhibiting
MIL-H-46855	Human Engineering Requirements for Military Systems, Equipment and Facilities
MIL-H-81200	Heat Treatment of Titanium and Titanium Alloys
MIL-D-81303	Design and Evaluation of Cartridges for Stores Suspension Equipment
MIL-C-81706	Chemical Conversion Materials for Coating Aluminum and Aluminum Alloys
MIL-C-81842	Connector Assemblies for Bomb Rack Electric Fuzing Provisions
MIL-F-83142	Forging, Titanium Alloys, Premium Quality
MIL-H-83282	Hydraulic Fluid, Fire Resistant, Synthetic Hydrocarbon Base, Aircraft, Metric, NATO Code Number H-537

MIL-STD-2088A

SPECIFICATIONS - Continued.

MILITARY

MIL-C-85049 Connector Accessories, Electrical, General
Specification for

STANDARDS

MILITARY

MIL-STD-100 Engineering Drawing Practices

MIL-STD-130 Identification Marking of U.S. Military Property

MIL-STD-454 Standard General Requirements for Electronic Equipment

MIL-STD-461 Requirements for the Control of Electromagnetic
Interference Emissions and Susceptibility

MIL-STD-462 Electromagnetic Interference Characteristics,
Measurement of

MIL-STD-704 Aircraft Electric Power Characteristics

MIL-STD-756 Reliability Modeling and Prediction

MIL-STD-838 Lubrication of Military Equipment

MIL-STD-882 System Safety Program Requirements

MIL-STD-889 Dissimilar Metals

MIL-STD-970 Standards and Specifications, Order of Preference for
the Selection of

MIL-STD-1385 Preclusion of Ordnance Hazards in Electromagnetic
Fields; General Requirements for

MIL-STD-1472 Human Engineering Design Criteria for Military Systems,
Equipment and Facilities

MIL-STD-1560 Insert Arrangements for MIL-C-38999 and MIL-C-27599
Electrical Circular Connectors

MIL-STD-1568 Materials and Processes for Corrosion Prevention and
Control in Aerospace Weapons Systems

MIL-STD-1760 Aircraft/Store Electrical Interconnection System

MIL-STD-2175 Casting, Classification and Inspection of

HANDBOOKS

MILITARY

MIL-HDBK-5 Volumes 1 and 2	Metallic Materials and Elements for Aerospace Vehicle Structures
MIL-HDBK-235-1	Electromagnetic (Radiated) Environment Considerations for Design and Procurement of Electrical and Electronic Equipment, Subsystems and Systems

(Unless otherwise indicated, copies of federal and military specifications, standards, and handbooks are available from DODSSP - Customer Service, Standardization Documents Order Desk, 700 Robbins Avenue, Building 40, Philadelphia, PA 19111-5094.)

2.1.2 Other Government documents, drawings, and publications. The following other Government documents, drawings, and publications form a part of this standard to the extent specified herein.

DRAWINGS

NAVAL SEA SYSTEMS COMMAND (CAGE Code 10001)

2263759	Latch, Spring Assembly
422872	Arming Wire, Single, MK 1 MOD 0, Arming Wire, Double, MK 2 MOD 0

(Unless otherwise indicated, copies of Naval Sea Systems Command drawings are available from the Naval Ordnance Station (Code 802), Louisville, KY 40214-5001.)

PUBLICATIONS

MILITARY

MIL-BUL-147	Specifications and Standards of Non-Government Organizations Released for Flight Vehicle Design and Construction
-------------	--

(Unless otherwise Indicated, copies of military bulletins are available from DODSSP - Customer Service Desk, Standardization Documents Order Desk, 700 Robbins Avenue, Building 41), Philadelphia, PA 19111-5094.)

NAVAL AIR SYSTEMS COMMAND

AR-43	Electromagnetic Compatibility Advisory Board; Requirement for
SD-24 Volume I	General Specification for Design and Construction of Aircraft Weapon Systems Fixed Wing Aircraft
SD-24 Volume II	General Specification for Design and Construction of Aircraft Weapon Systems Rotary Wing Aircraft

NAVAL AIR SYSTEMS COMMAND - Continued.

MS-2081 Switch, Arming Safety, Mark 122 Mod 0

(Copies of AR-43, SD-24, AND WS-2081 are available from the Naval Air Systems Command, Standardization Section (Code 51122E), Arlington, VA 22243-5110.1

NORTH ATLANTIC TREATY ORGANIZATION (NATO)

STANAG 3575 AA Aircraft Stores Ejector Racks

AIR STANDARDIZATION COORDINATING COMMITTEE (ASCC)

AIR STD 20/10 Ejector Release Units for Aircraft Stores

AIR STD 20/16 Electromagnetic Compatibility of Aircraft
Electro-explosive Sub-systems

AIR STD 20/17 Mechanical Connectors Between Stores and Suspension
Equipment for Arming and Associated Functions of Stores

AIR STD 20/18 Laboratory Tests for Stores Suspension Equipment

(Unless otherwise Indicated, copies of STANAGS and AIR STDS are available from DODSSP - Customer Service, Standardization Documents Order Desk, 700 Robbins Avenue, Building 4D, Philadelphia, PA 19111-5094.)

2.2 Order of precedence. In the event of a conflict between the text of this document and the references cited herein, the text of this document takes precedence. Nothing in this document, however, supersedes applicable laws and regulations unless a specific exemption has been obtained.

3* DEFINITIONS

3.1 Aircraft store. Any device intended for Internal or external carriage and mounted on aircraft suspension and release equipment, whether or not the item is Intended to be separated in flight from the aircraft. Aircraft stores are classified in two categories as follows:

- a. Expendable store. An aircraft store normally separated from the aircraft in flight such as a missile, rocket, bomb, nuclear weapon, mine, torpedo, pyrotechnic device, sonobuoy, signal underwater sound device, cargo drop container, drone, and other similar items.
- b. Non-expendable store. An aircraft store which is not normally separated from the aircraft in flight such as a tank (fuel and spray), line source disseminator, pod (refueling, thrust augmentation, gun, electronic-countermeasure, data link), multiple rack, target, and other similar items.

3.2 Latch. Those mechanisms which engage the BRU vertical supports to retain the store.

3.3 Loading. An operation that installs aircraft stores on the aircraft.

3.4 Primary release. The principal provisions for safe separation of stores or suspension items (or both) from the aircraft.

3.5 Secondary release. The emergency provisions for safe separation of stores or suspension items (or both) from the aircraft.

3.6 Sway bracing. That mechanism within the physical triaxial restraint system which partially or totally reacts to store yaw and pitching moment in addition to lateral store loads.

3.7 Vertical supports. The structural mating members of the BRU to the store. Typically hooks have been used to accomplish this function.

4. GENERAL REQUIREMENTS

4.1 BRU types. Carriage characteristics of BRU types are shown in Table I.

TABLE I. Carriage characteristics of BRU types.

Type	Vertical support spacing	Maximum carriage mass
I	14-inch	1450 lbs
II	14/30-inch	1450 lbs for 14-inch 5000 lbs for 30-inch

4.2 Selection of materials, specifications, standards and drawings. The selection of materials, standard parts, processes, corrosion protection, and design features significant in corrosion behavior shall be in accordance with the requirements of SD-24.

4.2.1 Materials. Materials shall conform to applicable specifications, be compatible with conditions of 4.3.9, and shall be as specified herein and on applicable drawings. Design shall make maximum use of standard (MS, AN, and MIL-STD) parts, materials and processes, rather than special or peculiar items. Materials which are not covered by government specifications or which are not specifically described herein, shall be of the best quality, suitable for the purpose intended. Particular care shall be given to close-fitting parts in the choice of both materials and corrosion prevention methods. Materials should be selected such that wet lubricants or preservatives are not required.

4.2.1.1 Metal parts. All metal parts shall be of the corrosion resistant type or treated in a manner to render them resistant to corrosion. Type AISI 431 corrosion resistant steel shall not be used. Unless suitably protected against electrolytic corrosion, dissimilar metals, as defined in MIL-STD-889, shall not be used in contact with each other. General design information governing usage of metals shall be as provided in MIL-HDBK-5.

4.2.1.1.1 Heat treatment. Heat treatment of aluminum, steel, and titanium parts shall be in accordance with MIL-H-6088, MIL-H-6875, and MIL-H-81200 respectively.

4.2.1.1.2 Castings. Castings shall conform to the requirements of MIL-STD-2175 with appropriate class, grade, and critical area notations. Aluminum alloy castings, used in critical strength applications, shall conform to the requirements of MIL-A-21180.

4.2.1.1.3 Forgings. Forgings shall conform to the requirements of MIL-F-7190, MIL-F-83142, or QQ-A-367 with appropriate grade and grain flow notations. Forgings, used in critical strength applications, shall conform to the requirements of MIL-F-7190 Grade A or MIL-A-22771.

4.2.1.2 Non-metallic components. Non-metallic components shall be designed for minimum deterioration caused by abrasion, exposure to sunlight, microorganisms, moisture, temperature extremes, fuel, hydraulic and

lubricating oil, grease, and salt spray. protection shall be provided for those non-metallic components that can endanger or jeopardize the function of the BRU due to strength degradation associated with abrasion, load or exposure-induced deterioration.

4.2.1.2.1 Reinforced plastic construction. Reinforced plastic materials, if required, shall be as specified for Type I materials in L-P-383 or meet the applicable requirements for fibrous composite construction in SD-24, and shall be of such character and quality as to be capable of withstanding all service conditions, as herein specified, without degrading the performance of the component of the BRU.

4.2.1.3 Lubrication. Lubricants and lubrication practices shall conform to the requirements of MIL-STD-838 and MIL-L-46010. Lubricants shall function satisfactorily throughout the temperature range from -70°F to +200°F. Choice of lubricants shall: (a) be compatible with non-metallic components, (b) not damage finishes adjacent to location of lubricant application, and (c) eliminate the need for frequent lubrication by field maintenance activities. If lubrication is required, choice of lubricants and practices shall be such that lubrication need be accomplished only during post deployment intermediate level maintenance (see 4.3.10.4.2).

4.2.1.4 Hydraulic fluids. Hydraulic fluids used in the BRU shall be in accordance with MIL-H-5606 or MIL-H-83282.

4.2.1.5 Fungus-proof materials. The materials used in the BRU shall be non-nutrients for fungi.

4.2.1.6 Potting compounds. Potting compounds shall comply with MIL-STD-454, requirement 47.

4.2.1.7 Corrosion protection. Corrosion protection practices employed shall be in accordance with the MIL-F-7179 requirements for exterior surfaces. Design shall make use of materials which preclude corrosion susceptibility under service environmental conditions without a requirement for hermetic sealing. Materials and processes for corrosion prevention shall meet the requirements of MIL-STD-1568.

4.2.1.8 Finishes. Protective coatings and finishes shall not crack, chip, or scale during normal service, or in the herein specified extremes of environmental conditions. Surface treatments, coatings, and finishes shall conform to MIL-S-5002 or surface treatments specified herein. General guidance in the application and control of organic finishes is provided in MIL-F-18264.

4.2.1.8.1 Anodizing. All non-fatigue critical aluminum and aluminum alloy parts, not subject to wear, shall have Type II anodic coatings in accordance with MIL-A-8625. Aluminum and aluminum alloy parts subject to wear shall have Type III anodic coatings in accordance with MIL-A-8625. On components where anodizing is detrimental to performance, MIL-C-81706 shall be used.

4.2.1.8.2 Chemical surface treatment. For aluminum and aluminum alloy parts not subject to wear, abrasion, or corrosion, chemical conversion surface treatment in accordance with MIL-C-5541 may be used in lieu of anodizing.

4.2.1.8 3 Plating. Plating should be avoided. When required, plating of steel surfaces shall be in accordance with the requirements of MIL-S-5002. Steel parts, not subject to wear, in contact with aluminum or aluminum alloys, shall be cadmium plated in accordance with QQ-P-416, Type II, Class 1, or MIL-C-8837, Type II, Class 1, or other plating process with equivalent or better properties and similar galvanic potential.

4.2.1.9 Electrical connectors. The connectors shall contain positive mating features to indicate completed connection and to prevent accidental shorting of or damage to contacts during mating of the plug and receptacle. Connectors shall contain peripheral grounding fingers that connect the two mating halves of the connector before pin and socket contacts make connection. The connector shall also contain provisions for terminating shield braid for electromagnetic interference protection. The aircraft, weapon and rack sides of the electrical connection shall contain socket-type contacts and the electrical adapter harness shall contain pin-type contacts. If there is no electrical adapter harness, then the aircraft or rack side of the electrical connection should contain socket-type contacts, and the weapon side shall contain pin-type contacts. The electrical connector selection shall be MIL-C-38999 series III, class W shell size 19, and using insert 19-32 of MIL-STD-1560. Connector accessories shall be in accordance with MIL-C-85049.

4.2.1.10 Wiring. All electrical wiring shall be selected and installed in accordance with MIL-W-5088.

4.2.1.11 Soldered or brazed connections. The soldering of contacts shall be in accordance with MIL-STD-454 requirement 5. When a brazing process is used, it shall be in accordance with MIL-B-7883.

4.2.2 Specifications and standards. Specifications and standards for necessary commodities and services not specified herein shall be selected in accordance with MIL-STD-970. A partial listing of approved MIL-STD-970 Group II non-government organization specifications and standards is furnished in MIL-BUL-147.

4.2.3 Drawings. Drawings shall be in accordance with MIL-STD-100 (see 6.3).

4.3 General design requirements.

4.3.1 BRU to aircraft installation. The BRU to aircraft installation in itself shall not require any special tools or equipment for mating and attachment.

4.3.2 Design factors of safety.

4.3.2.1 Yield. The BRU limit load shall be 1.15 times the design load. No permanent deformation shall be allowed after application of limit loads.

4.3.2.2 Ultimate. The BRU ultimate load shall be 1.50 times the design load. Failure of the BRU, upon application of the ultimate load, shall be defined as:

- a. Separation of the store from the BRU, or
 - a. Separation of the BRU from the aircraft
- Other structural breakage or permanent deformation of the BRU does not constitute failure at the ultimate load level.

4.3.2.3 Pressure system. Components of the pressure system, exposed to hydraulic or cold gas pressure only, shall be designed to a proof pressure of 1.15 and a burst pressure of 1.5 times the operational peak pressure of that system. Components of the pressure system exposed to hot gas pressure shall be designed to a proof pressure of 1.15 and a burst pressure of 2.0 times the operational peak pressure of that system. The lock shut firing shall not cause: (a) store release, (b) hazard to personnel, (c) system structural damage, or (d) unscheduled maintenance.

4.3.3 Structural load requirements. Load analyses shall be conducted to determine the design loads (see 6.3).

4.3.4 Stress analysis. A stress analysis shall be accomplished by using the loads generated in accordance with 4.3.3. Calculated margins of safety less than 0.20 for forged items and 0.33 for cast items shall be demonstrated by structural test. As a part of the stress analysis a summary of the critical margins of safety shall be supplied.

4.3.5 Service life. The BRU design objective shall be to meet or exceed an economically maintainable service life of 6000 flight hours. An economically maintainable service life is exceeded when the cost to repair the BRU is more than one-half the replacement cost. The BRU, in terms of store release, shall have a minimum design-service life of 500 store ejections prior to major overhaul.

4.3.6 Reliability. Mission reliability for a BRU shall be a minimum of 0.99 in accordance with MIL-STD-756. Mission reliability is the probability that the BRU will successfully eject stores within specified mission parameter. Shelf life of the BRU and all components shall be a minimum of five years, and shall be refurbishable following the minimum shelf life specified. Exclusive of shelf life, the service life of the BRU shall be a minimum of 10 years. A maximum number of parts shall have an infinite shelf life and a service life not less than that of the BRU.

4.3.7 Interfaces.

4.3.7.1 BRU to aircraft interface. The BRU to aircraft Interface shall be dependent on aircraft design and airframe backup structure to distribute the BRU stores load. The BRU mounting shall optimize the aircraft performance envelope, minimize weight and drag, and utilize optimum load paths. Design shall be tailored to existing aircraft support structure and shall provide ease of installation and removal. Physical interfaces between the BRU and the aircraft shall be defined in terms of dimensions and tolerances. Functional interfaces shall include the support, service, and ejection functions. Electrical interfaces shall specify BRU power and ejection signal requirements. All interface requirements shall comply with aircraft interface specifications.

4.3.7.2 BRU to store interface. Interface between the BRU and store shall include stores support, retention and the pre-launch, launch, and service functions. Physical interfaces including safe-arm mechanisms shall be specified in terms of dimensions and tolerances under both static and dynamic conditions. Grounding and shielding shall be provided. All interface requirements shall comply with aircraft interface specifications.

4.3.7.3 Electrical grounding interface.

4.3.7.3.1 BRU to aircraft structure grounding. The BRU structure shall be electrically grounded to the aircraft structure through the physical, mechanical interface of the two structures. The preparation of the conducting path and choice of mating surfaces composition, material, and electrical characteristics shall be available to the acquiring activity.

4.3.7.3.2 BRU Internal ground interface. An isolated common ground pin for the BRU and weapon electrical components shall be provided in the BRU to which each aircraft power source ground shall tie. The power return wires shall be twisted with the supply wires and the twist shall be approximately 155 twists per meter.

4.3.8 Human engineering. Human engineering shall comply with MIL-STD-1472, MIL-H-46855, and the following additional requirements:

- a. The value of the "antropometric 5th and 95th percentiles for armament groundcrew shall be as specified by the acquiring activity.
- b. Shall be capable of being handled, serviced, and transported outside of its aircraft installation without any requirement for ancillary equipment, such as carriers, bolts, and crates.
- c. Any positional indication and instructions located externally shall be flush with the general outside surface.
- d. All normal BRU functional operations shall be performed without the use of special tools.
- e. All normal functional operations and indications, such as cartridge installation, latching, loading, locking, and stray voltage checks, shall be available from both sides of the BRU.
- f. No components shall be accessible externally which would allow accidental or inadvertent operation of the BRU.
- g. All operation of the BRU shall require no more than two men at any one time.
- h. All services and normal function operations shall be accessible with the BRU latched and store restrained.
- i. Criteria shall be applied to the design to: (1) ensure that the equipment can be efficiently, safely, and reliably maintained and operated, (2) ensure that adequate handling provisions have been included, (3) minimize human error type failures, (4) ensure that design features will not constitute a hazard to personnel.
- j. Early design effort shall include identification of human factor variables which are most likely to require detailed study or research during later design stages, such as human performance requirements which may exceed human capabilities, degrade system objective, reflect possible unsafe practices, or may be prone to human error (see 6.3).

- k. Access with sufficient internal space shall be provided for servicing and adjusting.
- l. The design of the BRU shall have no protrusions or critically located components that could easily be damaged by normal handling or normal operation of the BRU outside of a shipping container.

4.3.9 Environmental and service conditions. The BRU shall meet the environmental requirements of MIL-T-7743 (AIR STD 20/18) and shall function under any or all combinations of the following general operating conditions:

- a. Altitude: From sea level to 70,000 feet.
- b. Temperature: From -70°F to +200°F. Transient temperatures are to be determined by the applicable aircraft detail specification.
- c. Humidity: Under all conditions of relative humidity at temperatures from -70°F to +200°F.
- d. High-g, vibration, and shock: Under all conditions of high-g, vibration, and shock that are present in aircraft during service operation.
- e. Contaminants: Under all conditions of service or storage.

4.3.10 Maintainability. The only scheduled maintenance the BRU shall require is preflight and post flight checkout and cleaning and the replacement of consumable items and associated services. The BRU shall be designed with sufficient simplicity to permit adjustments, repairs, and replacement of consumable goods and with comment accessibility which requires a minimum of maintenance-effort and facilities at all maintenance levels. The design shall provide for ease of assembly and disassembly with a minimal need for removal of hardware and special tools, test facilities and other support equipment for servicing. Design modularity of components shall be maximized for ease of replacement with minimum requirements for special skills. The module replacement concept shall be employed.

4.3.10.1 Maximum maintenance time. Design shall provide for:

- a. With BRU removed from the aircraft, a mean time to repair (MTTR) the BRU of one (1) hour and a two (2) hour maximum to include fault isolation to the component level, replacement of the failed component, and checkout.
- b. A maximum of 0.003 maintenance manhours (12 man seconds) per flight hour, for both organizational and intermediate inclusive, excluding replacement of expendable items and store loading.

4.3.10.2 Ejector system maintainability. If impulse cartridges are used as release and ejection energy sources, design shall provide for:

- a. Internal breech cleaning without removal of BRU assembly from the aircraft and without the use of special support equipment. BRU breech component removal shall be minimized to facilitate cleaning at the organizational maintenance level.

- b. Breech Installation and removal with a minimum of maintenance effort.
- c. A means other than removal of the breech cap or movement of the electrical connection to indicate cartridge installation.
- d. A positive retention feature shall be provided to maintain cartridge containers/breech caps in a secure position during flight.

4.3.10.3 Ejector system maximum maintenance time. The total servicing time for cleaning an ejector system should be 0.33 manhours (20 man minutes) maximum (see 4.3.10.4.1.1). Total the required for removal and installation of expendable items should be a maximum of 0.004 manhours (15 man seconds) for each energy source.

4.3.10.4 Maintenance plan. The BRU shall be designed to be maintained at the organizational and intermediate levels of maintenance at activities both ashore and afloat.

4.3.10.4.1 Organizational maintenance. Maintenance tasks performed at this level will be confined primarily to servicing and checkout of the BRU and shall be performed on a day-to-day basis.

4.3.10.4.1.1 Organizational maintenance tasks. Design shall allow for maintenance at this level to consist of the following:

- a. Preflight and postflight operations such as visual inspection, cleaning, servicing, and checkout. The ejector system shall not require cleaning or servicing prior to 50 ejections or 30 days whichever occurs first (see 4.3.10.3).
- b. Troubleshooting and testing to be conducted with the BRU mounted on the aircraft.
- c. Removal and replacement of designated components without requirements for alignment and adjustment or special tools.

4.3.10.4.2 Intermediate maintenance. Design shall allow for maintenance tasks performed at this level to be confined to support of organizational activities.

4.3.10.4.2.1 Intermediate maintenance tasks. Intermediate maintenance tasks shall consist of the following:

- a. Inspection: visual and dimensional inspections to determine corrosion damage and other defects reported by the organizational maintenance activity that would prevent reuse.
- b. Repair by adjustment, servicing, and replacement of components, assemblies, and subassemblies not within the capabilities of organizational maintenance.
- c. Checkout: electrical or functional

4.4 Interchangeability. All parts having the same part number shall be functionally and dimensionally interchangeable regardless of manufacturer. The item identification, manufacturer's part number, and part number

requirements of MIL-STD-100 shall govern the part numbers and changes thereto.

4.5 Identification and marking. Identification and marking shall be in accordance with MIL-STD-130. Nameplates for equipment identification shall be in accordance with MIL-P-15024, Size 3, Type A (c) or H, Style III and MIL-N-18307. All parts shall be marked with part numbers and, if applicable, lot numbers. Specifications on engineering drawings shall provide for part marking and shall indicate location of marking for accessibility.

5. DETAILED REQUIREMENTS

5.1 Loading (see 3.3) of stores. The BRU/store interface shall be designed with adequate space provisions to allow safe, rapid loading and off-loading of all applicable stores with a minimum of personnel, no peculiar equipment or tools required. This Interface shall provide good visibility and easy access to all controls, connections, switches and devices that relate to store loading/off-loading operations and positive visual determination of status of store installation. Consideration shall be given to store handling equipment installation (including manual loading equipment) and hook-lug entry angle during loading/off-loading operations. BRU geometry shall provide for the proper application of existing non-permanent hoisting adapters, hoisting devices including manual loading equipment, and loading carts or trucks as specified herein. All loading and off-loading or related equipment attachment or installation points shall be clearly marked and identified as to proper usage. For Navy aircraft applications, any BRU loading attachments or hoisting components shall be capable of withstanding a vertical limit loading of 2.67 g and carrier roll rates of $\pm 20^\circ$ with a 17 second period and pitch of $\pm 3^\circ$ with an 8 second period. BRU/store interface shall be compatible with the controls, load application range, and operational requirements of current applicable U.S. Inventory support equipment including Single Hoist Ordnance Loading System (SHOLS) (see MIL-I-8671). In addition, the Interface shall provide compatibility with manual loading equipment such that stores up to and including the 1,000 pound class can be loaded rapidly and safely with a minimum of personnel and without special tools or equipment. All connections or disconnections; i.e., arming wire installation, cartridge installation, fuzing connections, and safety interlock function required during this sequence of events, shall be accomplished after the store is structurally attached to the BRU without releasing the store attachment (AIR STD 20/17).

5.1.1 Support Equipment (SE). The BRU shall be designed to be capable of being installed, tested, serviced and maintained using standard SE and hand tools. Use of common hand tools shall be maximized. All SE shall be identified and grouped by maintenance level (Organizational and Intermediate).

5.1.2 Engagement, latching, and vertical support (see 3.7). The activation of the BRU vertical support latches (see 3.2) shall be automatic upon engagement of the store, independent of each other, and their position shall be visually discernible on both sides without requiring power. Overcenter latching devices, such as toggles and cams, if used, shall be designed and installed in such a way as to provide positive latching and unlatching and shall be insensitive enough to preclude inadvertent unlatching due to vibrations, tolerance build up, wear or structural deflections under load. Latching devices shall have a minimum travel of 15° from the latched to overcenter position. The vertical supports shall be designed such that they are either latched or unlatched with no in-between position. The vertical support system shall consist of two hooks to support 14-inch or 30-inch suspension store or four symmetrically positioned hooks for systems requiring 14 and 30-inch suspension. BRU lower surface to store upper surface clearance shall be as specified in MIL-A-8591 (STANAG 3575 M and AIR STD 20/10). After a store has been released, the latching system shall engage and latch the next loaded store without additional actions of the loading crew. The vertical latching force required to engage the store shall not exceed 25 pounds per hook for Type I BRUs and 50 pounds per hook for Type II BRUs. The vertical support shall be located as shown in Figure 1 and Figure 2.

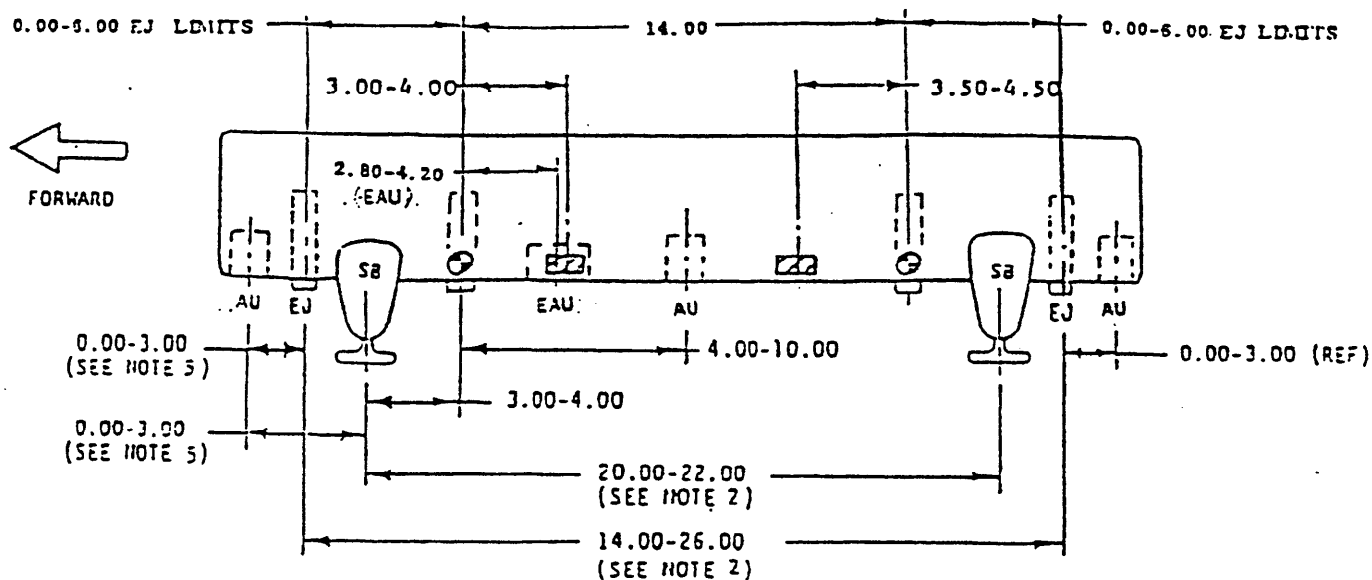

Notes:

1. Dimensions are in inches.
2. Dimensions are symmetrical about the midpoint of the 14-inch hook spacing.
3. Legend:
 - SB = Sway brace
 - AU = Mechanical fuze arming unit
 - EAU = Electrical fuze arming unit (MK 39 receptacle)
 - EJ = Ejector
 - ⊙ = Store suspension hook
 - ▨ = Positive arming attachment
4. All dimensional limit lines are located at Q. of feature.
5. Fore and aft A/Us shall be located 0.00-3.00 inches outboard of the outer most interface feature (sway brace or ejector piston).

Figure 1. 14-inch hook facing Type I bomb rack unit (BRU) geometric relationships.

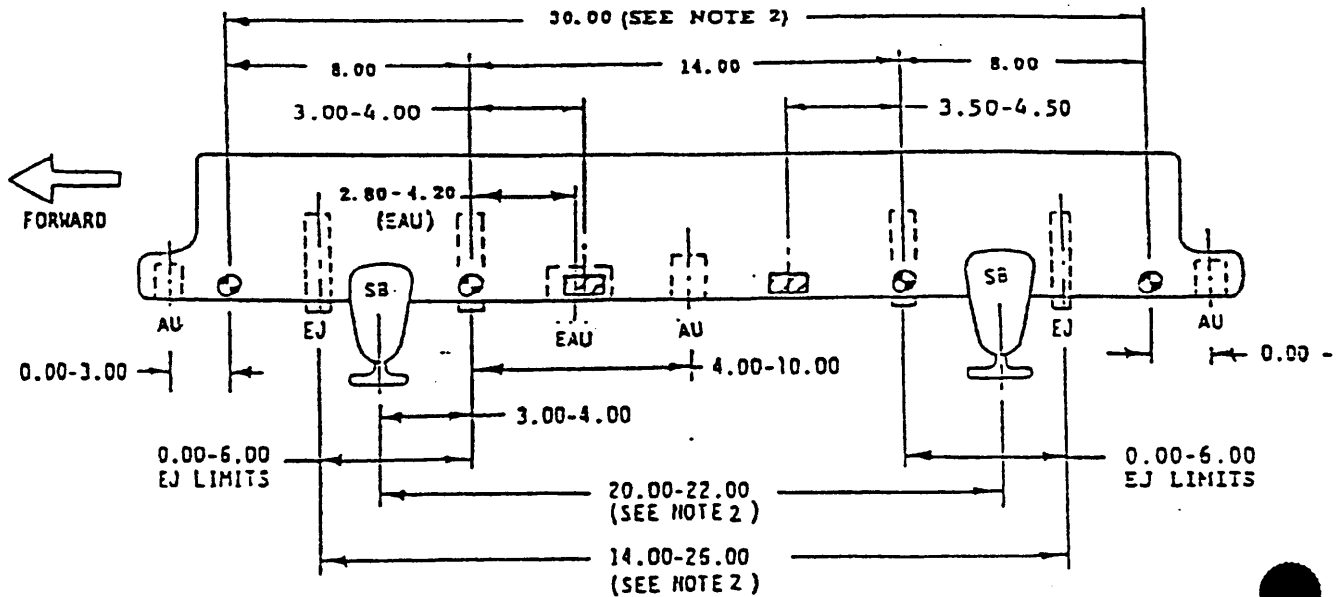

Notes:



1. Dimensions are in inches.
2. Dimensions are symmetrical about the midpoint of the 14-inch hook spacing.
3. Legend:
 - SB = Sway brace
 - AU = Mechanical fuze arming unit
 - EAU = Electrical fuze arming unit (MK 39 receptacle)
 - EJ = Ejector
 -  = Store suspension hook
 -  = Positive arming attachment
4. All dimensional limit lines are located at ϕ of feature.

Figure 2. 14/30-inch hook spacing Type II, bomb rack unit (BRU) geometric relationships.

5.1.3 Store sensing. The BRU shall provide a store present/store not present indication. The sensing device shall have the capability for remote store status indication. Store sensing shall ensure that a hung store retained by only one hook is sensed as a store present. The sensing device shall provide a logic signal to the aircraft control system to enable it to deactivate all release and control signals to the BRU when no store is present. The BRU, required by the statement of work or the purchase specification, shall, by sensing the store not present, deactivate all release and control signals within the BRU. Neither of the preceding conditions shall affect mechanical operations needed to load or unload a store. The BRU shall provide the capability of release and control system check and test without overriding the sensing devices. The BRU sensing, when installed, shall be protected from damage at all times.

5.1.3.1 Store sensing failure mode. Mechanical failure of the store sensing device shall be in the fail-safe mode (store not present). The store sensing device shall be such that the primary electrical failure mode is also the fail-safe mode.

5.1.4 Fuzing and arming control. The BRU design shall include Integral mechanical and electrical fuze Arming Units (AUs) to control the "SAFE/ARM" condition of fuzes on appropriate conventional stores. The BRU shall be capable of Independent operation of each AU. All arming wire to AU connection *points* shall be easily accessible with the store fully latched and restrained. All locations shall be as specified in 5.1.4.1 and 5.1.4.2, and Interface connections shall comply with MIL-A-8591. Additionally, the BRU design shall include positive arming attachment points as specified in 5.1.4.3.

5.1.4.1 Mechanical fuze AUs. The BRU shall provide three continuous duty electromechanical AUs to control the store mechanical fuze(s) "SAFE/ARM" status. The AUs shall be mechanically linked to the BRU (AIR STD 20/17) latching mechanism with provisions for the following:

- a. An energized AU shall retain an arming wire with a force of 600 pounds.
- b. With vertical latching mechanism closed, retain arming wire to preclude pre-load problems during captive carriage (AU unenergized and rack hooks closed).
- c. Allow zero retention force on arming wire when store is released and AUs are "safe" or unenergized.
- d. AU locations shall permit easy insertion and removal of standard arming wire loops, Drawing 422872, with the store restrained.
- e. Shall not be susceptible to inadvertent operation due to shock, vibration, or store ejection per MIL-T-7743.
- f. Retain arming wires after an "Armed" drop, even after the BRU is deenergized, until arming wires are manually removed.
- g. The AU shall be located on the BRU lower longitudinal centerline.
- h. The centerline of the AU arming loop retaining loop mechanism shall be between 1 and 2.5 inches above the store contour.

- i. The mechanical fuze AUs shall be located as shown on Figures 1 and 2.
- j. AU solenoid design shall comply with MIL-S-4040.
- k. Each AU shall operate reliably at a nominal 28 volts direct current (Vdc) over a voltage range of 18 to 33 Vdc at a maximum of 250 milliamperes per MIL-STD-704 emergency voltage range.
- l. A temporary voltage surge, up to ± 45 Vdc maximum, across the arming unit power input terminals shall not damage the AU's ability to operate properly and shall conform to the requirements of 5.1.9.2.

5.1.4.2 Electrical fuze AU. The BRU shall provide an electrical fuze AU as specified in MIL-C-81842 at the location as shown in Figure 1 and Figure 2 to ensure compatible electric fuze functioning with the MK 122 arming safety switch as specified in WS-2081. There shall be an Interlock function provided between the BRU release linkage and fuze charging line, whereby the electrical AU senses correct linkage movement representing properly intended store release, before the electrical pulse is permitted to enter the electrical fuze connector. The electrical fuze arming circuit shall be such that the predominant failure mode of the electrical fuzing shall be in the fail-safe mode (not fuzed). The fuze circuit shall be designed such that a hung store by either hook will not arm/fuze the device. Adjacent to the electrical arming unit shall be a positive arming attachment (see 5.1.4.3) compatible with the MK 122 arming safety switch. Vertical access and clearance shall be provided to permit MK 122 arming safety switch connection to the electrical A/U by hand with the store latched and restrained.

5.1.4.3 Positive arming attachment. Positive arming attachment points shall be provided at four locations, two on each side of the BRU, as shown on Figures 1 and 2. A latch spring assembly, as specified on Drawing 2263759 or equivalent, shall be installed at the positive arming attachment points. The axis of the latch shall be located 1.125 inches above the surface of the store. The latch spring assembly shall be mounted so that its long dimension is parallel to the axis of the store and the movement required to open the latch is always forward. The axis of the latch spring assembly shall not be more than 2.0 inches off the longitudinal centerline of the BRU.

5.1.5 Sway braces. Automatic or semi-automatic activation of the store sway braces (see 3.6) shall be provided for all stores after independent activation of both hooks supporting the store. Sway braces shall be located symmetrically about hooks as shown on Figures 1 and 2 and laterally within the reinforcement area of MIL-A-8591 (STANAG 3575 AA and AIR STD 20/10). The sway braces shall be capable of reacting the design loads without the use of adapters. For standardization purposes, the sway braces and related BRU systems shall accommodate store diameter as follows:

<u>SUSPENSION</u>	<u>DIAMETER</u>
14-inch	8.0 to 20.0 inch
14/30-inch	8.0 to 20.0 inch for 14-inch 8.0 to 30.0 inch for 30-inch

Sway braces shall be limited so that they cannot apply excessive loads to the store or BRU to prevent store release. The sway braces shall be limited to a

maximum angle of 70° between the BRU vertical axis and the sway brace line of action. After all sway braces have been activated, the store shall be held securely in all three axes until separation of the store. The application of the sway braces at any point shall have a centering action on the store that tends to keep the store symmetric about the BRU vertical axis. The contact of the sway braces to the store shall exhibit at least line contact on a store conforming to MIL-A-8591. After release of the store, the sway braces should reset for accepting the next store. The sway braces shall not require any scheduled maintenance nor be susceptible to damage by sand, dust, or supersonic airflow impingement. The sway braces shall be capable of interfacing with stores having reinforced areas as follows:

- a. For 14-inch suspension only stores: 4.0 inches circumferentially on either side of the lug centerline.
- b. For 14/30-inch suspension stores: 5.0 inches circumferentially on either side of the lug centerline.

5.1.6 Safety Interlock. The BRU shall contain a safety Interlock to mechanically prevent the release of the vertical support and interrupt the means of initiating release power to the BRU (STANAG 3575 AA and AIR STD). Unlocking the safety interlock shall require two distinct motions. The first shall remove the interruption of the means of initiating the release power. The second shall remove the mechanical lock. The safety interlock shall be designed to be operated either manually or with normal aircraft power. When operated with aircraft power, the time required to operate the safety interlock shall not exceed 10 seconds. The interlock should be positioned in the BRU such that its location and function gives maximum advantage in preventing inadvertent release as a result of any single point mechanical or electrical failure. The interlock shall be operable (lock and unlock) and provide remote indication of status. The interlock shall be operable by one man locally without power or tools and shall be capable of full manual operation within a maximum of 10 seconds either way (lock or unlock). The BRU local interlock position indicator shall be mechanically linked to the interlock, be visible from a distance of 15 feet during daylight hours, and be incapable of indicating a locked condition with either vertical support disengaged. The design shall ensure that the Interlock can only be applied when the 14-inch and 30-inch vertical supports are fully latched. power for remote interlock operation shall be defined in 5.2.8 and 5.2.9, it shall be derived from a normal aircraft power source, shall not require more than 10 amperes and shall not be required for more than 10 seconds. The design shall not require the use of manually insertable or removable parts to accomplish the Interlock function. For a given combination of vertical supports and release actuation circuits, which make up a single BRU unit, there shall not be more than one interlock system. Unlocking of the interlock shall not release the vertical supports nor provide release initiation power. The complete Interlock system shall be totally contained within the structure of the BRU.

5.1.6.1 Safety Interlock override system. For nuclear classified BRU systems, means shall be provided to override all mechanical and electrical vertical support safety Interlock functions. This override system shall be utilized if the Interlock system fails. Design shall meet all requirements for emergency jettison regardless of primary interlock status. (NOTE: Emergency jettison action will require the simultaneous release of all store locks and supports in less than 0.50 seconds). The override of the interlock

shall simultaneously accomplish all of the mechanical and electrical unlocking functions of the vertical support safety interlock system. The operation of the override shall not release the store. The override shall have the capability of remote indication of status and operation. The power for the override system operation shall come from a source that is separated from and is controlled independent of the primary safety interlock. The override system design and functional requirements shall consider and be compatible with all operational modes and environments consistent with the aircraft mission requirements.

5.1.6.2 Safety Interlock electrical sensing. The safety interlock sensing system shall provide open ground discretely to identify the status of the safety interlock. These interlocks discretely shall be available for use by the aircraft control system. The sensing system shall be designed such that no single failure shall cause the aircraft to sense an erroneous safe condition.

5.1.7 Store release and ejection system. Primary store ejection release shall occur at all aircraft attitudes with all store restraining mechanisms removed simultaneously and the vertical supports driven to the release position by compatible sequencing of the release and store ejection mechanisms (STANAG 3575 M and AIR STD 20/10). The store ejection velocity, release attitude and resultant reaction forces shall be applied through the ejector pistons except in its gravity release mode.

5.1.7.1 Cartridge initiation. If cartridges are used, the release and ejection system shall be initiated remotely by independent aircraft electrical sources (primary and secondary). Independent initiation pulses shall follow separate wiring to the installed cartridges. The release and ejection system shall be wired to provide simultaneous initiation of both impulse cartridges from either source as detailed in Figure 3. Capability shall be provided to guarantee the sympathetic firing (ignition of one cartridge shall ignite the other) of either impulse cartridge by the other without sacrificing ejector performance.

5.1.7.2 Cartridges. If cartridges are employed in the ejector system, the cartridges and ejector system shall be designed, but not limited to, the following requirements:

- a. Two cartridges shall be utilized.
- b. The ejector system shall be actuated by the initiation of any combination of CCU-43/B, CCU-44/B, or CCU-45/B cartridges.
- c. Cartridge interface and utilization shall comply with MIL-D-81303. (Cartridge geometry is specified in MIL-D-81303.)
- d. Cartridge power sources shall provide a minimum of 3 amperes at 28 Vdc and meet the requirements in MIL-STD-704. Each power source shall use an independent driver for each of the two cartridges. These drivers, when not activated, shall be capable of withstanding the transient voltages generated when the cartridge bridge wires burn open due to activation by the primary or secondary power source. The average cartridge functioning time versus the applied current data for the CCU-43/B, CCU-44/B, or CCU-45/B cartridges are as specified in Figure 4.

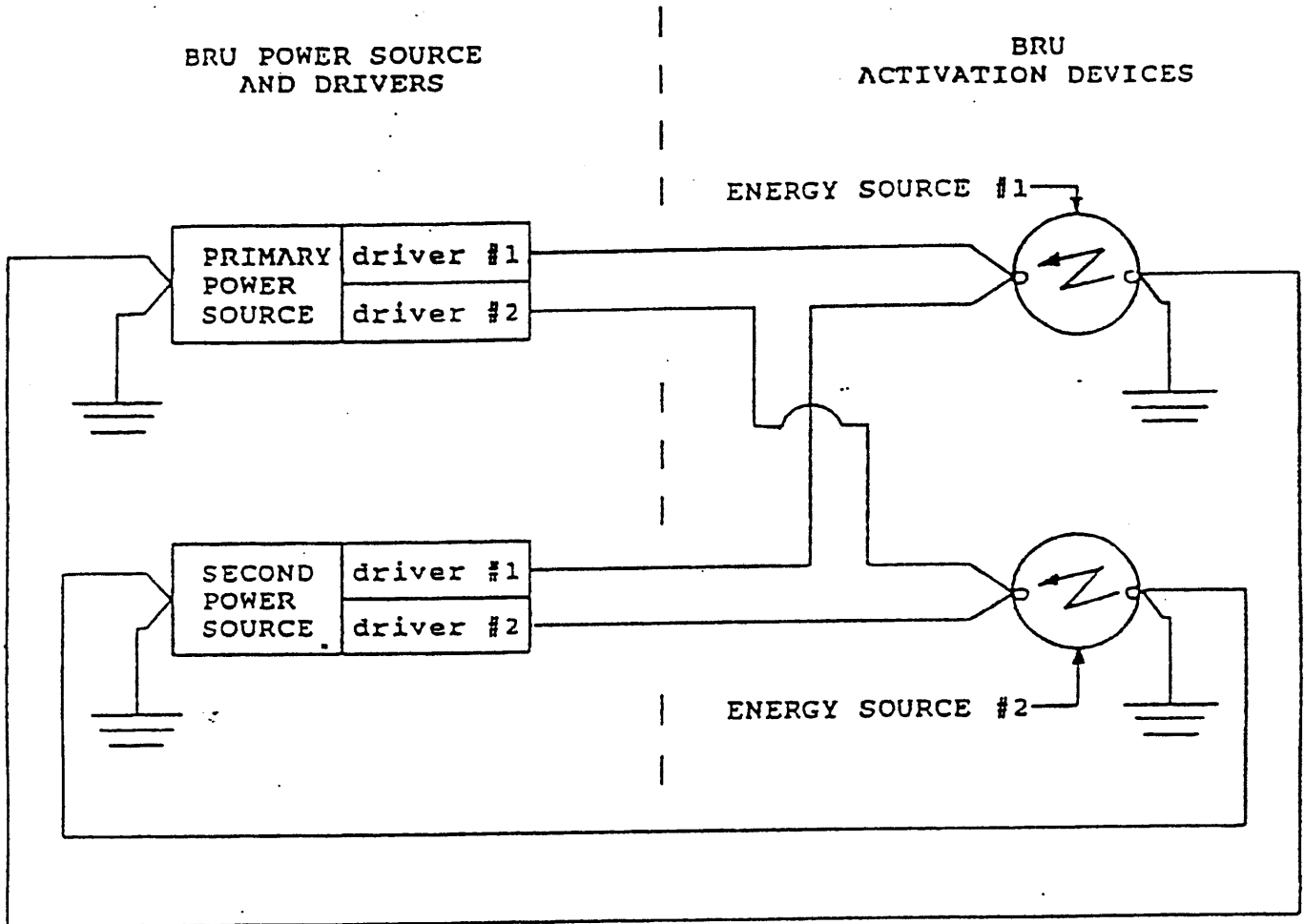

FIGURE 3. Wiring schematic to achieve primary and secondary release.

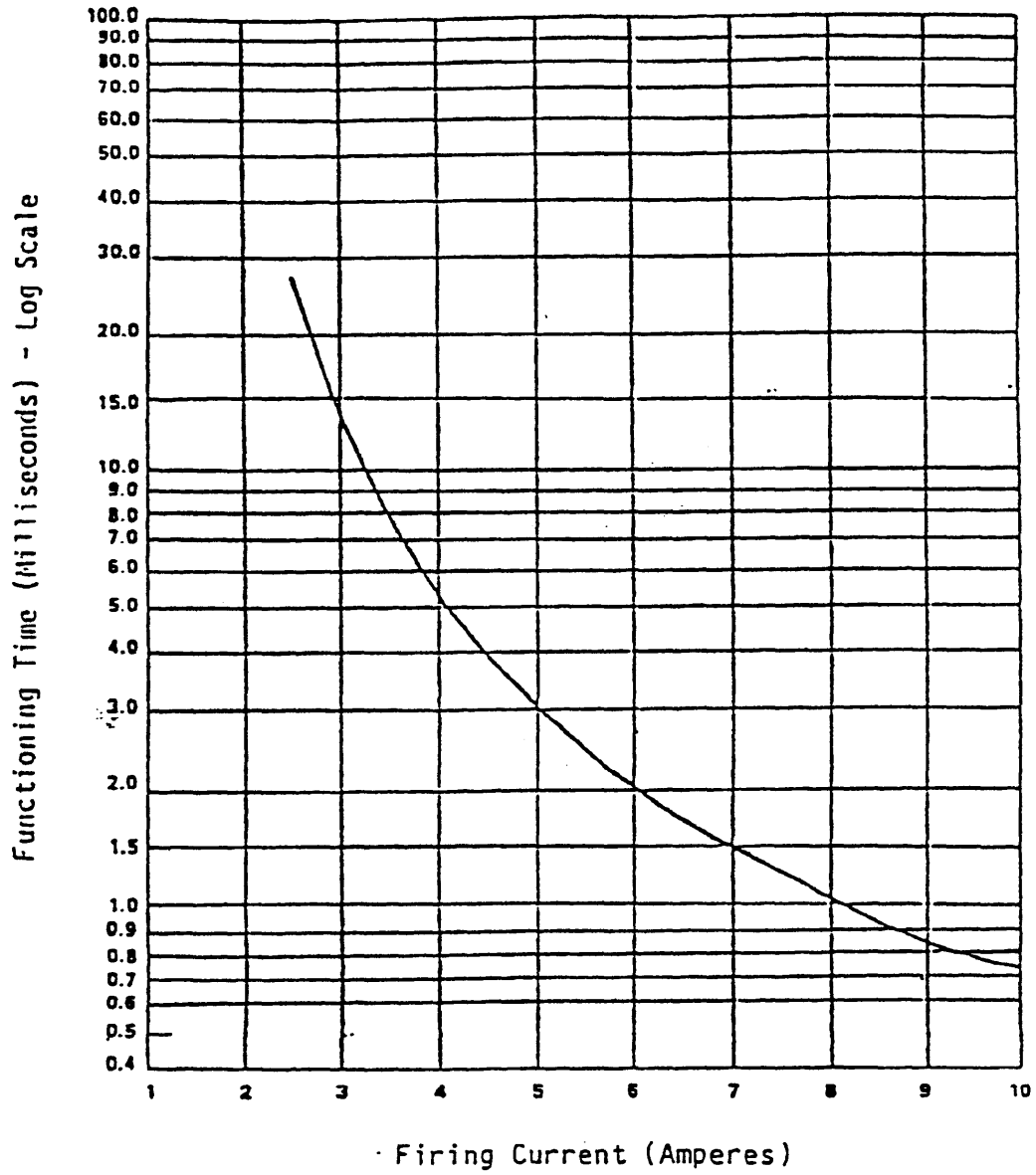

FIGURE 4. CCU-43/B, CCU-44/B, CCU-45/B cartridges
functioning time vs applied current

5.1.7.3 Cartridge firing pin. The cartridge firing pin configuration and characteristics shall be as follows:

- a. Shank diameter of 0.092 ± 0.002 Inch.
- b. Point of 90° included angle with 0.005 Inch diameter maximum flat.
- c. Hardness, Rockwell 59 HRC to 62 HRC.

5.1.7.4 Cartridge breech. The diameter of the cartridge breech (or cartridge holder if used) shall be a straight bore of $1.081 + .003 - .000$ inches over its full length. Any taper existing within these limits shall be uniform over the full length of the breech or cartridge holder, with the maximum diameter occurring at the end adjacent to the cartridge flange. The surface finish on the cartridge breech shall be a minimum of 32 microinches, root mean square (rms). Cartridge breech design shall provide cartridge firing pressure in the range of 3,000 to 25,000 PSI, with suitable confinement of the cartridge main charge propellant for reproducible performance. Means shall be provided at the end of the ejector piston cycle to safely vent the remaining gas pressure. To comply with a 0.008 manhour (30 man second) cartridge removal and installation time for all cartridges of the BRU, provisions shall be made for quick installation of cartridges, rapid cap insertion and positive integral extraction of expended cartridges to facilitate unaided manual cartridge removal. System design shall provide for:

- a. Internal cleaning without removal of BRU from the aircraft and without the use of special support equipment.
- b. Breech removal and installation, for cleaning, at the organization level, shall require a minimum of effort.
- c. A means other than removal of components or movement of electrical connections to indicate cartridge installation.
- d. A means other than removal to indicate an expended cartridge.
- e. Breech cleaning shall be required only after 50 ejections or 30 days, whichever occurs first (see 4.3.10.4.1.1)
- f. Firing pin to breech cartridge bore true positioning of 0.015 inch diameter.
- g. Full support of cartridge base upon installation and during firing.
- h. Firing pin/cartridge electrode contact force ranging from 40 pound-force (lbf) to 100 lbf.
- i. Preclude shorting to ground of electrode upon cartridge installation.

5.1.7.5 Ejection force. Ejection force shall be applied to a store in such a manner as to provide adequate store velocity, pitch attitude and pitch rate to ensure safe store separation from the aircraft. The maximum ejection force that should be applied to a store by the rack is 22,500 pounds. The maximum ejection force shall be distributed nearly between the pistons. The pressure applied on a store shall not exceed 15,000 psi. The BRU may have the capability for ejecting stores with greater force than identified herein, but

facilities shall exist in the BRU to reduce the performance to the identified limits. Ejection reaction forces shall be compatible with BRU mounting and aircraft station capabilities. Store ejection force application shall be as shown in Figure 1 and Figure 2. Application of ejection forces shall not induce impact loading that will damage the BRU.

5.1.7.6 BRU to aircraft reaction. Reaction resulting from BRU ejection of store(s) should be limited to 1.0 g per foot per second of end-of-stroke store ejection velocity. To the maximum extent possible, the BRU design should limit the reaction resulting from BRU ejection to meet this goal.

5.1.7.7. Separation velocity. The applied energy output from the ejection system shall provide an end of stroke separation velocity (including the effects of gravity) of 20 ft/sec nominal for all 500 pound stores. Standard deviation of the velocity (at constant temperature) based on a minimum of 10 operations of the BRU shall be as specified by the contracting activity.

5.1.7.8 Ejection pistons. After store ejection, the ejection pistons shall automatically retreat within the BRU structure to accept the next store.

5.1.8 Safety in design. An active safety program shall be implemented and specific requirements introduced into the BRU design and development.

5.1.8.1 BRU safety program. Safety shall be achieved through preengineering safety analyses and evaluation of design concepts. This effort shall provide surveillance, control and visibility to ensure that no design creates a condition that can cause personnel injury, damage, or loss of equipment (see 6.3). The safety program shall meet the objectives of:

- (1) Eliminate all Category I and II hazard levels and provide control of all Category III hazard levels commensurate with mission objectives. To select an optional corrective action and to determine whether to implement the corrective action, a tradeoff study shall be conducted. Final implementation shall be acceptable to the acquiring activity.
- (2) Ensure the subassemblies or components cannot be misassembled or misinstalled.

5.1.8.1.1 Safety program functions. The safety program shall contain the following MIL-STD-882 requirements, as a minimum:

- a. Provide for qualitative systems analyses to identify potential hazards.

Close attention shall be given to those design features and characteristics that have created safety related problems on previous systems.

- b. Submit periodic safety program status reports identifying all category hazard levels, including probability of occurrence (see 6.3). Probabilities may be based on mean time between failures (MTBF) data and past failure histories. If a corrective safety program has been identified and is to be corrected within the scope of the contract, the corrective action also shall be included in these reports.

- c. The safety program personnel shall participate in all design reviews as part of the overall safety effort.

5.1.8.1.2 Failure modes and criticality effects analysis. During the BRU development process, the BRU shall be analyzed for possible failure modes resulting from anticipated environmental and load conditions. This analysis shall evaluate the likelihood of occurrence of identified failure modes. For each failure mode identified, a determination shall be made of the effect of the part, circuit, or unit in question and of the ultimate significance of this effect relative to overall system safety. This analysis shall include a discussion of the factors inherent in the design or the quality program that will minimize the likelihood of occurrence of those failures having the most significant effect on system safety. This analysis shall be updated as design configuration and load conditions change and shall be reviewed by the contracting activity.

5.1.8.1.3 Inadvertent release. Inadvertent release or arming of a store shall not occur due to the failure or malfunction of one single component of the BRU.

5.1.8.1.4 Locked shut functioning. In a locked shut functioning of the BRU, energy dissipation shall not be accomplished in any manner which could lead to personnel hazard, structure damage, or both.

5.1.8.1.5 Driven Items. Except for the ejector pistons no driven items shall be externally exposed.

5.1.8.1.6 Impulse cartridges. Impulse cartridge venting into the following areas shall be unacceptable:

- a. Area where direct exposure of personnel to hot gas exhaust performing normal duties would occur.
- b. Internally in any vicinity where venting would cause degradation of the BRU such as the electrical wiring and mechanical equipment.

5.1.9 Electromagnetic Environmental Effects (E²). The control of E³ shall be as specified in 5.1.9.1 through 5.1.9.9

5.1.9.1 Electromagnetic Compatibility (EMC) program. A system EMC program in accordance with the requirements of MIL-E-6051 shall be applied (see 6.3). This program shall be supported by an Electromagnetic Compatibility Advisory Board (EMCAB) established in accordance with the requirements of AR-43. The specifics for the EMC program effort are provided in the Electromagnetic Compatibility Program Plan (EMCPP).

5.1.9.2 Electromagnetic Interference (EMI). The BRU electrical system shall meet the requirements of MIL-STD-461 Class A1b using the test methods described in MIL-STD-462. The following MIL-STD-461 tests are applicable: CE01, CE03, CE07, CS02, CS02, CS06, CS11, RE01, RE02, RS01, RS02, and RS03 which is modified by Tables II, III, and IV (see 6.3).

5.1.9.2.1 Electromagnetic Pulse (EMP). The BRU shall meet the EMP requirements of MIL-STD-461 using test method CS11 of MIL-STD-462.

TABLE II. RSQ3 test levels.

Frequency	Signal	Modulation	Field (peak) 3/
14 KHz - 1 MHz	CW	None	20 V/m
1 MHz - 18 GHz	CW	None	200 V/m
18 GHz - 40 GHz	CW	NONE	20 V/m
1 MHz - 18 GHz	PAM	Table III 1/	200 V/m
18 GHz - 40 GHz	PAM	Table III 1/	20 V/m
33 GHz - 34 GHz	PAM	Table III 1/	200 V/m

TABLE III. Worst-case modulation over required frequency band.

Step	Frequency sub-band	Initial set frequency	Field 3/ (peak)	Modulation 2/ (source wave)
A	1.0 MHz - 10.0 MHz	5.0 MHz	200 V/m	30 Hz, 300 Hz, 3 KHz, 30 KHz
B	10.0 MHz - 100.0 MHz	50.0 MHz	200 V/m	30 Hz, 300 Hz, 3 KHz, 30 KHz
C	100.0 MHz - 1.0 GHz	500.0 MHz	200 V/m	30 Hz, 300 Hz, 3 KHz, 30 KHz
D	1.0 GHz - 10.0 GHz		See D1 or D2 where applicable	
D1	1.0 GHz - 8.0 GHz	5.0 GHz	200 V/m	3 KHz, 30 KHz, 300 KHz
D2	8.0 GHz - 10.0 GHz	9.0 GHz	200 V/m	3 KHz, 30 KHz, 300 KHz
E	10.0 GHz - 18.0 GHz	15.0 GHz	200 V/m	3 KHz, 30 KHz, 300 KHz
F	18.0 GHz - 40.0 GHz	30.0 GHz	20 V/m	300 Hz, 3 KHz, 30 KHz
G	33 GHz - 34 GHz	33 GHz	200 V/m	300 Hz, 3 KHz, 30 KHz

TABLE IV. Modulation f

Source r (50 percent
300 Hz
300 Hz
250 Hz
See D1 or
100 KHz
250 KHz
60 KHz
2 KHz
2 KHz

- 1/ Tests from 1.0 MHz - 10.0 GHz, from 10.0 GHz - 40.0 GHz, and from 33 GHz - 34 GHz shall be performed by sub-bands defined under worst-case modulation condition. If no susceptibility exists in the sub-band specified, the modulation in Table IV shall be used. The procedures for determining the modulation required is defined in 2/.
- 2/ (a) Adjust generator to initial set frequency for the specified sub-band.
 (b) Perform RSQ3 tests at the specified field level for each modulation specified in Table III.
 (c) Using worst-case modulation determined in step (b), perform tests over frequency sub-band at the specified field strength. If the susceptibility condition was encountered in step (b), use the modulation specified in Table IV for the specified frequency.
- 3/ $V/m(P) \times \sqrt{\text{Duty Cycle}} = V/m(AV)$. For CW $V/m(P)_{rms} = V/m(AV)_{rms}$.

5.1.9.3 Electromagnetic Vulnerability (EMV). The BRU electrical system shall meet the EMV requirements of MIL-E-6051 when subjected to the EMV environment of MIL-HDBK-235-1. Contact the Naval AIR Systems Command (AIR-51641), Arlington, VA 22243 for additional information.

5.1.9.4 Lightning protection. The BRU system shall meet the requirements of the EMC program to provide compliance with the requirements of MIL-E-6051 and MIL-B-5087 for protection against lightning.

5.1.9.5 Bonding and grounding. The BRU system shall meet the requirements of the EMC program to provide compliance with the requirements of MIL-E-6051 and MIL-B-5087.

5.1.9.6 Wiring and cabling. The BRU shall meet the requirements of the EMC program to provide compliance with the requirements of MIL-E-6051.

5.1.9.7 Static electricity. The BRU system shall meet the requirements of the EMC program to provide compliance with the requirements of MIL-E-6051 for static electricity effects.

5.1.9.8 Hazards of Electromagnetic Radiation to Ordnance (HERO). The BRU system shall meet the HERO requirements of MIL-STD-1385 (STANAG 3575 M and AIR STD 20/16).

5.1.9.9 Coupling Factor (CF). The BRU shall be considered a potential coupling device which may provide entry for excessive Radio Frequency (RF) energy from the external environment, through the BRU into the remainder of the weapon-system and possibly the entire aircraft system. The BRU shall utilize sufficient shielding, filtering or such other EMI suppression techniques as may be required to ensure that the external electromagnetic (EM) environment shall not be coupled through the BRU. The external EM environment is as defined in MIL-HDBK-235-1.

5.2 Detailed electrical requirements.

5.2.1 General. The bomb rack shall conform to the following electrical requirements stated herein. Additionally, all signals shall conform to the EM requirements of 5.1.9. The rack designer may utilize all or a subset of the signals listed in the paragraphs listed.

5.2.2 Rack structural ground. The rack shall provide a conductive path from all metallic parts of its outer skin to the structural ground pin in the rack connector. This conductive path shall be bonded to class H requirements of MIL-B-5087 and shall meet the requirements for structure ground as defined in MIL-STD-1760.

5.2.3 Nose arm. This aircraft signal is the primary signal to the arming unit solenoid located in the front of the rack. Activation of this signal shall cause the forward arming solenoid to activate and retain the forward mechanical arming wire upon store release. This function shall operate from 28 Vdc/open discrete and shall not require more than 0.250 amperes on a continuous basis.

5.2.4 Tail arm. This aircraft signal is the primary signal to the arming unit solenoid located in the rear of the rack. Activation of this signal shall cause the aft arming solenoid to activate and retain the aft mechanical

arming wire upon store release. This function shall operate from 28 Vdc/open discrete and shall not require more than 0.250 amperes on a continuous basis.

5.2.5 Electrical fuzing. This aircraft signal, when present upon store release, shall be transmitted directly to the store. After both hooks open, connection shall be made to arm the store. The devices used to transfer these voltages (+ 195 Vdc, + 300 Vdc) shall be capable of closing and carrying momentary current of one ampere.

5.2.6 Primary release (see 3.4) command. This electrical signal to the rack shall be the primary store release initiator. The mechanical release of the store from the rack may be initiated by either impulse cartridge(s) or solenoid.

5.2.6.1 Impulse cartridge. When utilized with impulse cartridges as specified in 5.1.7.2 b, this signal shall cause initiation of the primary store release cartridge in the rack to open the store retention hooks and extend a piston in the ejector assembly. The power requirements for activation of the cartridge shall be as shown on Figure 4, with power as defined in MIL-STD-704.

5.2.6.2 Solenoid release. When utilized with solenoid release activation, this signal shall energize the primary store release solenoid in the rack initiating operation of the release mechanism. This function shall operate from a 28 vdc/open discrete and shall not require more than five amperes for more than 75 seconds.

5.2.7 Secondary release (see 3.5) command. This signal to the rack is the secondary store release initiator should a failure occur in the primary release command circuit. This signal may be applied simultaneous with the primary release command. The characteristics of the secondary release devices shall be identical to those of the primary release devices.

5.2.8 Auxiliary release command. This signal to the rack shall initiate a gravity release from the rack by release of the retention hooks. This operation shall not exceed the requirements of a single cartridge activation, shown on Figure 4, when supplied with power as defined in MIL-STD-704.

5.2.9 In-Flight Operable Bomb Rack Lock (IFOBRL) Lock command. This signal to the rack shall cause the application of power to electrically drive the safety interlock actuator (see 5.1.6) to perform the IFOBRL function. This function places a mechanical obstruction in the release linkage to lock the rack, thereby preventing store release by the hooks even if activation of the release mechanism should occur. The electrically driven IFOBRL actuator mechanism shall operate from a 28 Vdc/open discrete and shall require less than 250 milliamperes for no longer than 10 seconds.

5.2.10 IFOBRL unlock command. This signal to the rack shall cause an electrically driven IFOBRL actuator to remove the obstruction that is placed in the release linkage to allow the hooks to open. The unlock mechanism shall operate from a 28 Vdc/open discrete and shall require less than 250 milliamperes for less than 10 seconds.

5.2.11 IFOBRL Lock monitor. This signal from the rack shall indicate that the IFOBRL actuator has fully locked the rack. This open/ground discrete shall be capable of sinking 250 milliamperes.

5.2.12 IFOBRL unlock monitor. This signal from the rack shall indicate that the IFOBRL actuator has unlocked the rack. This open/ground discrete shall be capable of sinking 250 milliamperes.

5.2.13 IFOBRL lock override. This signal, when present, shall provide a means of overriding the safety mechanism of the in-flight lock linear actuator. This discrete is a 28 Vdc signal from the aircraft. The override mechanization shall not require more than 10 amperes and shall not require this current for more than 10 milliseconds.

5.2.14 IFOBRL Cartridge Activated Device (CAD) auxiliary unlock command. If it is desired to use a CAD to override the IFOBRL, the power required shall be in accordance with MIL-STD-704, 28 Vdc normal or emergency and the current shall be as shown on Figure 4.

5.2.15 Hook status. This signal from the rack shall conform the opening of the rack store hooks. This discrete signal is a ground/open signal which changes state only when both fore and aft hooks have been opened. Nominal current sink capability of the devices used for this function shall be 250 milliamperes.

5.2.16 Rack present. This signal from the rack shall indicate the Presence of the rack on the aircraft. This discrete signal is a ground signal used to confirm that the rack is attached to the aircraft. Nominal current sink capability shall be 250 milliamperes.

5.2.17 Store sense switch. This signal from the rack shall indicate that a store is present on the rack. This signal shall be a ground/open and shall be capable of sinking 250 milliamperes. Store sensing shall ensure that a store retained by one hook shall be sensed as a store present.

5.2.18 Rack power/master arm. This signal to the rack shall be available to supply power to those mechanisms or devices requiring currents higher than those available for listed command functions such as higher current devices which will use the commands listed to activate a power switching device within the rack to supply the current for the function. This function shall operate from a 28 Vdc/open discrete and shall require a current not greater than 5 amperes on a continuous basis.

6. NOTES

(This section contains Information of a general or explanatory nature which may be helpful, but is not mandatory.)

6.1 Intended use. This standard is intended to be used in establishing general criteria for the design and development of a bomb rack unit for carriage and powered ejection release of airborne stores (excluding air-to-air missiles) on 14 or 30-inch suspension from fixed wing aircraft.

6.2 Issue of DODISS. When this standard is used in acquisition, the applicable issue of the DODISS must be cited in the solicitation (see 2.1.1).

6.3 Consideration of data requirements. The following data requirements should be considered when this standard is applied on a contract, The applicable Data Item Descriptions (DID's) should be reviewed in conjunction with the specific acquisition to ensure that only essential data are requested/provided and that the DID's are tailored to reflect the requirements of the specific acquisition. To ensure correct contractual application of the data requirements, a Contract Data Requirements List (DD Form 1423) must be prepared to obtain the data, except where DOD FAR Supplement 227.405-70 exempts the requirement for a DD Form 1423.

<u>Reference Paragraph</u>	<u>DID Number</u>	<u>DID Title</u>	<u>Suggested Tailoring</u>
4.2.3	DI-DRPR-81000	Product drawings and associated lists	- -
4.2.3	DI-DRPR-81001	Conceptual design drawings and associated lists	- -
4.2.3	DI-DRPR-81002	Developmental design drawings and associated lists	- -
4.3.3	O1-S-30588	Loads analysis reports (aircraft/missiles)	- -
4.3.8j	DI-HFAC-80242	Human factors design and analysis report	- -
5.1.8.1	DI-SAFT-80100	System safety program plan	- -
5.1.8.1.1b	DI-SAFT-80101	System safety hazard analysis report	- -
5.1.9.1	DI-R-7096	Electromagnetic compatibility program plan	- -
5.1.9.2	DI-EMCS-80199	Electromagnetic interference control plan	- -
5.1.9.2	DI-EMCS-80200	Electromagnetic interference test report	- -
5.1.9.2	DI-EMCS-80201	Electromagnetic interference test plan	- -

The above DID's were those cleared as of the date of this standard. The current Issue of DOD 5010.12-L, Acquisition Management Systems and Data Requirements Control List (AMSDL), must be researched to ensure that only current, cleared DID's are cited on the DD FORM 1423.

6.4 International standardization agreements. Certain provisions of this document are the subject of international standardization agreements. When change notice, revision, or cancellation of the document is proposed which

will affect or violate the International agreement concerned, the preparing activity shall take appropriate reconciliation action through international standardization channels, including departmental standardization offices, if required. Table V identifies the paragraphs containing the requirements for the International standardization agreements.

TABLE V. Paragraphs containing international standardization agreements.

Paragraph	Paragraph title	International standardization
4.3.9	Environmental and service conditions	AIR STD 20/18
5.1	Loading of stores	Air STD 20/17
5.1.2	Engagement, latching and vertical support	STANAG 3575 AA AIR STD 20/10
5.1.4.1	Mechanical fuze arming units	AIR STD 20/17
5.1.5	Sway brace	STANAG 3575 AA AIR STD 20/10
5.1.6	Safety interlock	STANAG 3575 M AIR STD 20/10
5.1.7	Store release and ejection system	STANAG 3575 MI AIR STD 20/10
5.1.9.8	Hazards of Electromagnetic Radiation to Ordnance (HERO)	STANAG 3575 AA AIR STD 20/16

6.5 Subject term (key word) listing.

- Positive arming attachment
- Store Interface
- Store release and ejection system
- Sway braces

6.6 Changes from previous issue. Marginal notations are not used in this revision to identify changes with respect to the previous issue due to the extensiveness of the changes.

CONCLUDING MATERIAL

Custodians:
Army - AV
Navy - AS
Air Force - 11

Preparing activity:
Navy - AS

(Project No. 1095-0226)

Applicable International Organizations:
North Atlantic Treaty Organization (NATO)
Air Standardization Coordinating Committee (ASCC)

STANDARDIZATION DOCUMENT IMPROVEMENT PROPOSAL

INSTRUCTIONS

1. The preparing activity must complete blocks 1, 2, 3, and 8. In block 1, both the document number and revision letter should be given.
2. The submitter of this form must complete blocks 4, 5, 6, and 7.
3. The preparing activity must provide a reply within 30 days from receipt of the form.
NOTE: This form may not be used to request copies of documents, nor to request waivers, or clarification of requirements on current contracts. Comments submitted on this form do not constitute or imply authorization to waive any portion of the referenced document(s) or to amend contractual requirements.

I RECOMMEND A CHANGE:

1. DOCUMENT NUMBER
 ML-STD-2088A

2. DOCUMENT DATE
 (YYMMDD) 94/05/09

3. DOCUMENT TITLE
 BOMB RACK UNIT (BRU), AIRCRAFT, GENERAL DESIGN CRITERIA FOR

4. NATURE OF CHANGE *(Identify paragraph number and include proposed rewrite, if possible. Attach extra sheets as needed.)*

5. REASON FOR RECOMMENDATION

6. SUBMITTER

a. NAME *(Last, First, Middle Initial)*

b. ORGANIZATION

c. ADDRESS *(Include Zip Code)*

d. TELEPHONE
(Include Area Code)

7. DATE SUBMITTED
 (YYMMDD)

(1) Commercial:
 (2) DSN:
(If Applicable)

8. PREPARING ACTIVITY

a. NAME
 COMMANDER
 NAVAL AIR WARFARE CENTER
 AIRCRAFT DIVISION

b. TELEPHONE NUMBER *(Include Area Code)*
 (1) Commercial (2) DSN
 (908) 323-7488 624-7488

c. ADDRESS *(Include Zip Code)*
 CODE SR3
 HIGHWAY 547
 LAKEHURST, NJ 08733-5100

IF YOU DO NOT RECEIVE A REPLY WITHIN 45 DAYS, CONTACT:
 Defense Quality and Standardization Office, 5203 Leesburg Pike, Suite 1403, Falls Church, VA 22041-3466
 Telephone (703) 756-2340 DSN 289-2340